

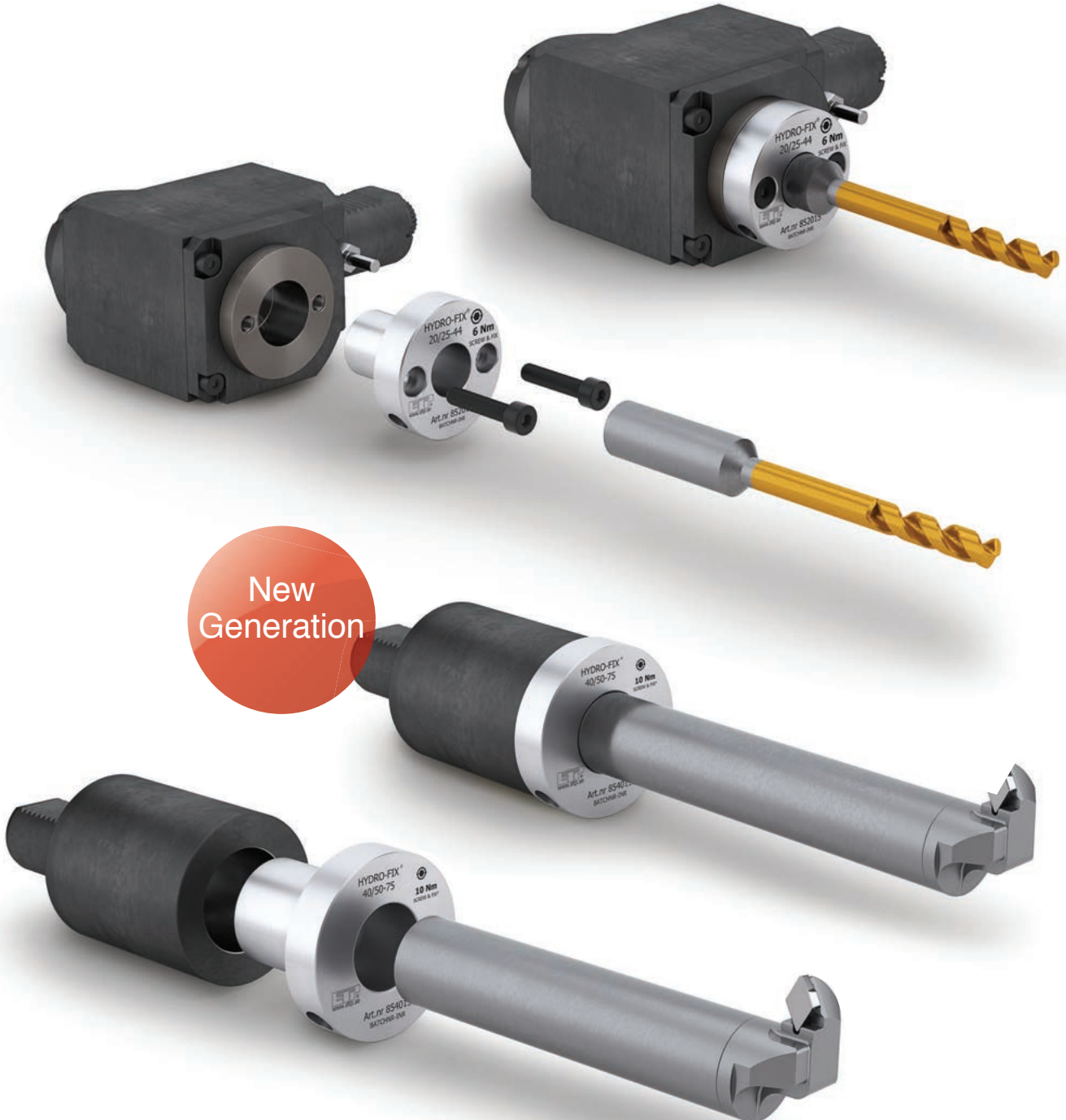

ETP HYDRO-FIX®

Hydraulic high precision clamping sleeve



New Generation

ETP HYDRO-FIX clamping sleeves are excellent for boring bars for internal and external turning as well as in driven toolholders. With the one screw fix system it is quick and easy to handle.

The clamping is uniform around the tool and therefore the tool life is improved. The clamping system absorbs and reduces vibration, improves surface quality and best of all increases your productivity!

BENEFITS & FEATURES

- Reduced vibrations
- Increased speed and/or feed
- Improved surface quality
- Increased tool life
- Quick and easy handling
- Increased overhang possible
- Safe clamping of solid carbide tools. No risk of damages

ETP HYDRO-FIX®

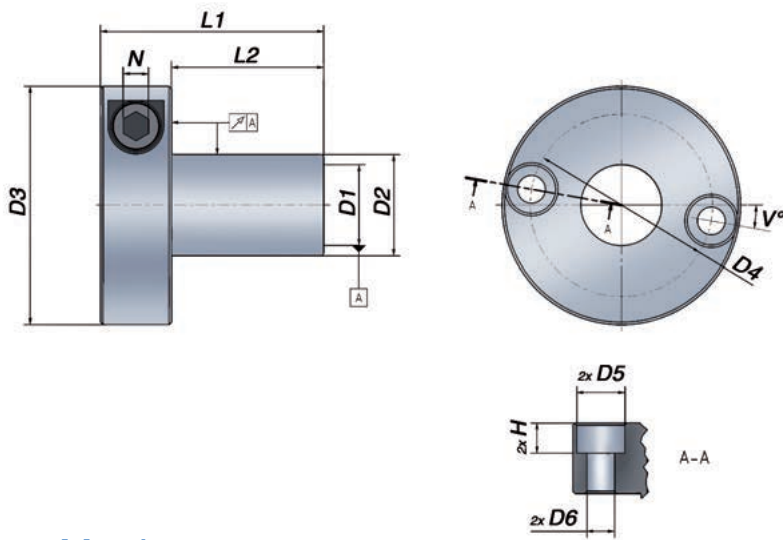

Metric range

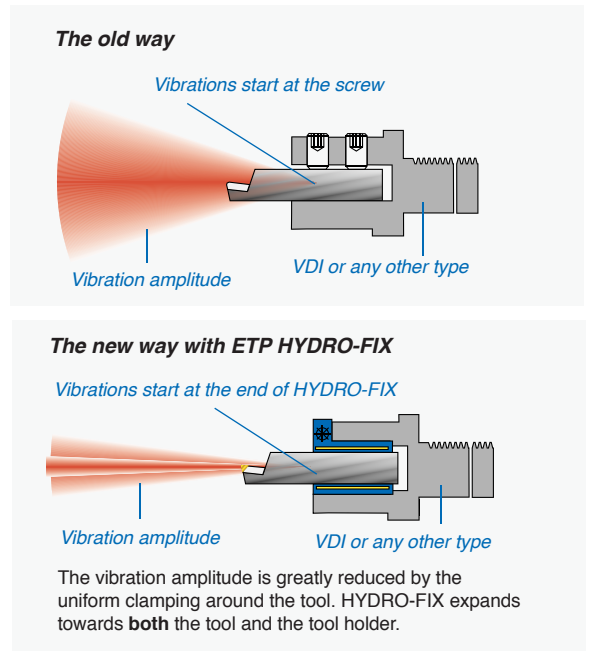

Technical Specification

Part no.	Item description	Dimensions, mm					Recommended screws DIN 915, 12.9					Pressure screw		Runout mm	T* Nm	Weight kg
		D1*	D2**	D3	L1	L2	D4	D5	D6	H	V°	N	Tt*** Nm			
● 851215	HYDRO-FIX 12/16-38	12	16	43.5	38	24	28	9.5	5.5	6	5	5	6	0.006	60	0.15
● 851615	HYDRO-FIX 16/20-44	16	20	47	44	30	36	9.5	5.5	6	10	5	6	0.006	165	0.17
● 852015	HYDRO-FIX 20/25-44	20	25	52	44	30	36	11	6.5	7		5	6	0.006	260	0.21
● 852515	HYDRO-FIX 25/32-48	25	32	59	48	34	44	11	6.5	7		5	6	0.010	160	0.30
○ 852515+	HYDRO-FIX 25/32-48+	25	32	59	48	34	44	11	6.5	7		5	6	0.010	350	0.30
● 853215	HYDRO-FIX 32/40-53	32	40	69.5	53	39	52	11	6.5	7		5	6	0.010	320	0.43
○ 853215+	HYDRO-FIX 32/40-53+	32	40	69.5	53	39	52	11	6.5	7		5	6	0.010	630	0.43
○ 854015	HYDRO-FIX 40/50-69	40	50	79	69	55						5	6	0.015	320	0.96
○ 854215	HYDRO-FIX 42/50-76	42	50	89	76	56						8	10	0.015	800	0.94
○ 855015	HYDRO-FIX 50/60-80	50	60	98.5	80	60						8	10	0.015	800	1.23
○ 856015	HYDRO-FIX 60/80-90	60	80	115.5	90	70						8	10	0.015	800	2.34

Inch range

Technical Specification

Part no.	Item description	Dimensions, inch					Recommended screws DIN 915, 12.9					Pressure screw		Runout inch	T* ft-lb	Weight kg
		D1*	D2**	D3	L1	L2	D4	D5	D6	H	V°	N	Tt*** Nm			
● 851315	HYDRO-FIX 1/2"/5/8"-38	0.500	0.625	1.713	1.496	0.945	1.102	0.374	0.217	0.236	5	0.197	6	0.00024	44	0.15
● 851515	HYDRO-FIX 5/8"/3/4"-44	0.625	0.750	1.850	1.732	1.181	1.417	0.374	0.217	0.236	10	0.197	6	0.00024	121	0.17
● 851915	HYDRO-FIX 3/4"/1"-44	0.750	1.000	2.047	1.732	1.181	1.417	0.433	0.256	0.276		0.197	6	0.00039	191	0.21
● 852615	HYDRO-FIX 1"/1 1/4"-48	1.000	1.250	2.323	1.890	1.339	1.732	0.433	0.256	0.276		0.197	6	0.00039	118	0.30
○ 852615+	HYDRO-FIX 1"/1 1/4"-48+	1.000	1.250	2.323	1.890	1.339	1.732	0.433	0.256	0.276		0.197	6	0.00039	258	0.30
● 853115	HYDRO-FIX 1 1/4"/1 1/2"-53	1.250	1.500	2.736	2.087	1.535	2.047	0.433	0.256	0.276		0.197	6	0.00039	236	0.43
○ 853115+	HYDRO-FIX 1 1/4"/1 1/2"-53+	1.250	1.500	2.736	2.087	1.535	2.047	0.433	0.256	0.276		0.197	6	0.00039	465	0.43
○ 853915	HYDRO-FIX 1 1/2"/2"-69	1.500	2.000	3.110	2.717	2.165						0.197	6	0.00059	118	1.06
○ 855115	HYDRO-FIX 2"/2 1/2"-80	2.000	2.500	3.996	3.150	2.362						0.315	10	0.00059	590	1.42
○ 856315	HYDRO-FIX 2 1/2"/3"-93	2.500	3.000	4.685	3.661	2.874						0.315	10	0.00059	885	1.98

***) T_t = Recommended tightening torque for the screw in Nm! Further tightening does not increase the pressure.
 *) T = Transmittable torque using a h6 cylindrical tool, full depth (L1) insert.

For dimensions 12 mm (1/2") – 20 mm (3/4"):

When using a non-cylindrical tool/toolbar – we recommend the use of a reducing sleeve to avoid plastic deformation of ETP HYDRO-FIX.

Information:

- *) Tool/toolbar shank h6 or h7 can be used.
- **) Recommended tolerance of toolholder bore - H7. Balanced by design. For use above 3 000 rpm - we recommend individual balancing.

Accessories:

- Use preset Torque Wrench to ensure correct mounting of tools.
- 6 Nm - Part no. 19050
- 10 Nm - Part no. 19054



Digital Spirit Level

- For easy toolbar alignment use the ETP Digital Spirit Level
- Part no. 885010

